



Carbon pTR Instructions	
Part Numbers	
• Fuel rail kit for Carbon pTR/pTR LT1/LT2	70640.00

Instructions to add optional port fuel injection to pTR/Carbon pTR LT1/LT2.

1. Remove pTR lid.
2. Insert provided drill bushing in the injector boss.
3. Use the provided drill bit to drill through the nylon material to the port.



4. Deburr drill hole on the port side.
5. You may notice some minor voids in the casting within the drill hole. This is a normal part of the nylon casting process and does not affect performance.
6. Reinstall the upper plenum following the Carbon pTR assembly instructions.
7. Install the fuel rail mounting brackets using the provided self-tapping torx head screw and torque to 44in-lbs.

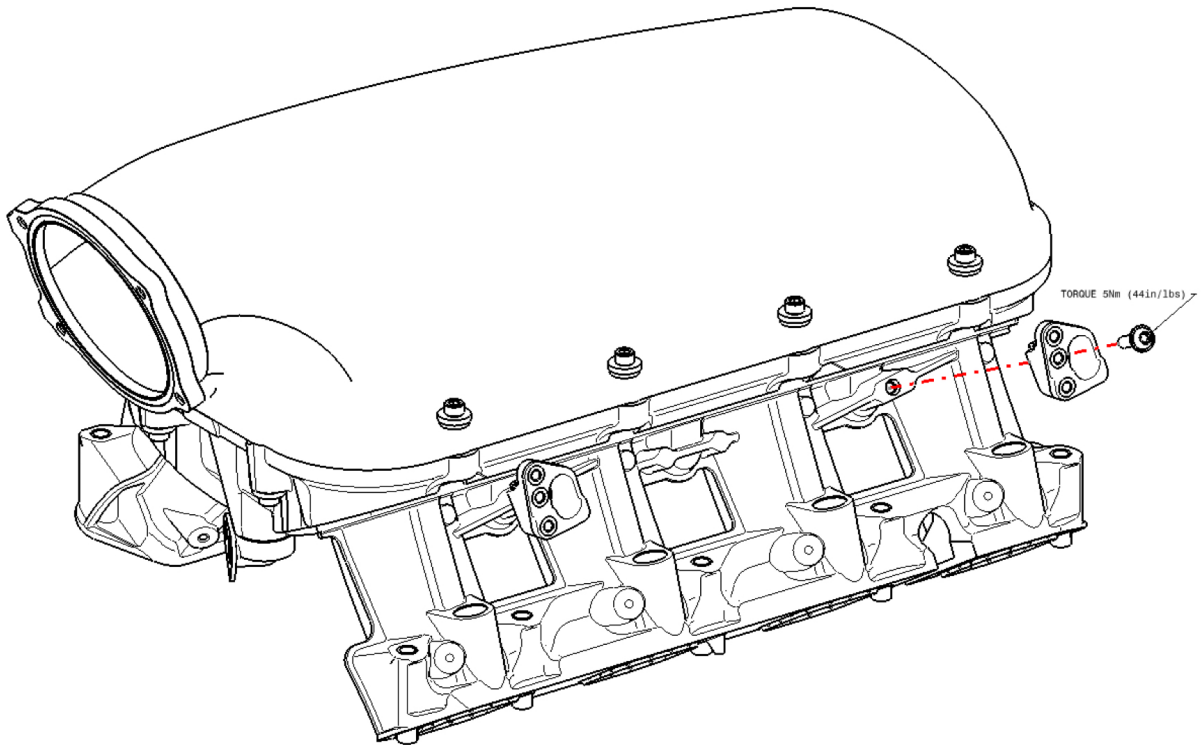

8. EV6-style extended tip injectors are recommended.
9. When installing EV6 injectors use the low fuel rail mounting position.

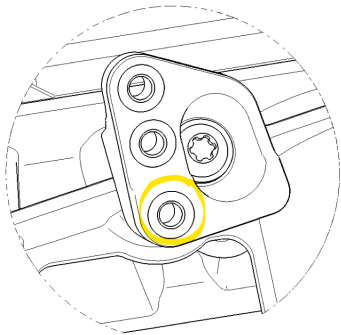

If you are using EV1 injectors use the high position. When mounting the fuel rail in the high or middle position use a 1/8" spacer between the fuel rail and the bracket.

10. Torque fuel rail mounting bolts to 90 in-lb.

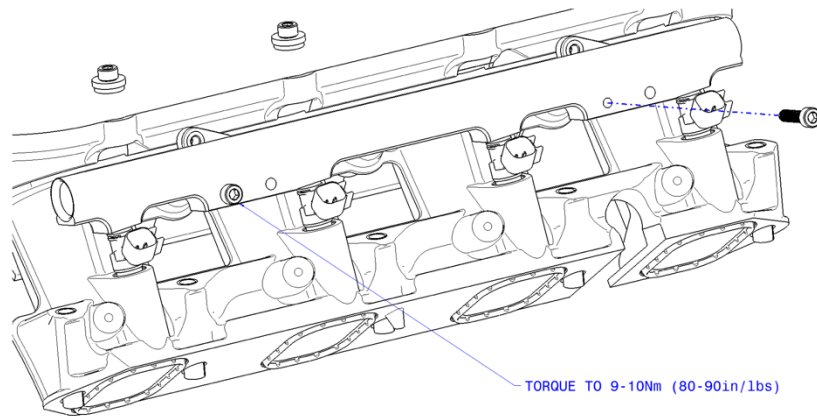

11. Install -8ORB fittings and plugs in the ends of the fuel rails as needed for your application.
12. Install intake manifold following the Carbon pTR assembly instructions
13. Pressurize your fuel system and check for leaks.